

FINAL NEET(UG)-2020 EXAMINATION

(Held On Wednesday 14th OCTOBER, 2020)

PHYSICS

TEST PAPER WITH ANSWER & SOLUTION

136. The E.M. wave with shortest wavelength among the following is

- (1) Ultraviolet rays (2) X-rays
 (3) Gamma-rays (4) Microwaves

Ans. (3)

Sol. Gamma-rays

137. The angular speed of the wheel of a vehicle is increased from 360 rpm to 1200 rpm in 14 second. Its angular acceleration is

- (1) $2\pi \text{ rad/s}^2$ (2) $28\pi \text{ rad/s}^2$
 (3) $120\pi \text{ rad/s}^2$ (4) 1 rad/s^2

Ans. (1)

Sol. $t = 14 \text{ s}$

$$\omega_0 = \frac{360}{60} \text{ rps} = 12 \pi \text{ rad s}^{-1}$$

$$\omega = \frac{1200}{60} \text{ rps} = 40 \pi \text{ rad s}^{-1}$$

$$\omega = \omega_0 + \alpha t$$

$$\Rightarrow \alpha = \frac{\omega - \omega_0}{t} = \frac{28\pi}{14} = 2\pi \text{ rad s}^{-2}$$

138. What happens to the mass number and atomic number of an element when it emits γ -radiation?

- (1) Mass number decreases by four and atomic number decreases by two.
 (2) Mass number and atomic number remain unchanged.
 (3) Mass number remains unchanged while atomic number decreases by one.
 (4) Mass number increases by four and atomic number increases by two.

Ans. (2)

Sol. No change

139. The angle of 1' (minute of arc) in radian is nearly equal to

- (1) $2.91 \times 10^{-4} \text{ rad}$ (2) $4.85 \times 10^{-4} \text{ rad}$
 (3) $4.80 \times 10^{-6} \text{ rad}$ (4) $1.75 \times 10^{-2} \text{ rad}$

Ans. (1)

Sol. $1' = \left(\frac{1}{60}\right)^\circ = \frac{1}{60} \times \frac{\pi}{180} \text{ radian}$

$$= 2.91 \times 10^{-4} \text{ radian}$$

140. The magnetic flux linked with a coil (in Wb) is given by the equation

$$\phi = 5t^2 + 3t + 16$$

The magnitude of induced emf in the coil at the fourth second will be

- (1) 33 V (2) 43 V
 (3) 108 V (4) 10 V

Ans. (2)

Sol. $\phi = 5t^2 + 3t + 60$

$$|\varepsilon| = \left| \frac{d\phi}{dt} \right| = 10t + 3$$

At $t = 4 \text{ sec.}$

$$|\varepsilon| = 40 + 3 = 43 \text{ volt}$$

141. The electric field at a point on the equatorial plane at a distance r from the centre of a dipole having dipole moment \vec{p} is given by

($r \gg$ separation of two charges forming the dipole, ϵ_0 - permittivity of free space)

(1) $\vec{E} = \frac{\vec{P}}{4\pi \epsilon_0 r^3}$ (2) $\vec{E} = \frac{2\vec{P}}{4\pi \epsilon_0 r^3}$

(3) $\vec{E} = -\frac{\vec{P}}{4\pi \epsilon_0 r^2}$ (4) $\vec{E} = -\frac{\vec{P}}{4\pi \epsilon_0 r^3}$

Ans. (4)

Sol. $\vec{E} = -\frac{k\vec{P}}{r^3}$

$$\vec{E} = -\frac{\vec{P}}{4\pi \epsilon_0 r^3}$$

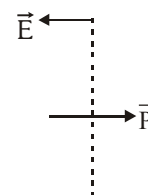

- 142.** A plano-convex lens of unknown material and unknown focal length is given. With the help of a spherometer we can measure the
- (1) focal length of the lens
 - (2) radius of curvature of the curved surface
 - (3) aperture of the lens
 - (4) refractive index of the material

Ans. (2)

Sol. Spherometer → used to measure radius of curvature of the curved surface.

- 143.** A light bulb and an inductor coil are connected to an ac source through a key as shown in the figure below. The key is closed and after sometime an iron rod is inserted into the interior of the inductor. The glow of the light bulb

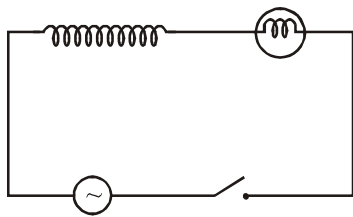

- (1) decreases
- (2) remains unchanged
- (3) will fluctuate
- (4) increases

Ans. (1)

Sol. $z = \sqrt{R^2 + X_L^2}$

$X_L \uparrow, Z \uparrow, I \downarrow$

- 144.** The efficiency of a Carnot engine depends upon
- (1) the temperature of the sink only
 - (2) the temperatures of the source and sink
 - (3) the volume of the cylinder of the engine
 - (4) the temperature of the source only

Ans. (2)

Sol. $\eta = 1 - \frac{T_2}{T_1}$

T_1 = temperature of source

T_2 = temperature of sink

- 145.** Out of the following which one is a forward biased diode ?

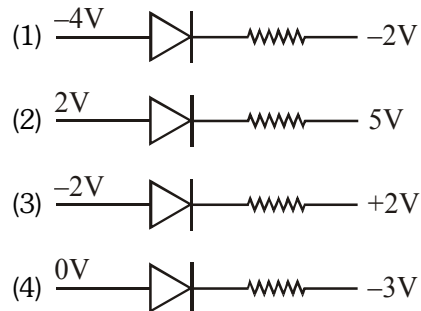

Ans. (4)

Sol. In forward bias $V_P > V_N$

- 146.** For the circuit shown in the figure, the current I will be

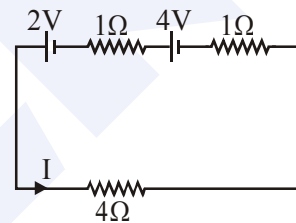

- (1) 0.75 A
- (2) 1 A
- (3) 1.5 A
- (4) 0.5 A

Ans. (2)

Sol. $I = \frac{2+4}{4+1+1} = \frac{6}{6} = 1 \text{ Amp}$

- 147.** Two coherent sources of light interfere and produce fringe pattern on a screen. For central maximum, the phase difference between the two waves will be
- (1) zero
 - (2) π
 - (3) $3\pi/2$
 - (4) $\pi/2$

Ans. (1)

Sol. For central maximum, the phase difference between the two waves will be zero.

- 148.** The total energy of an electron in the n^{th} stationary orbit of the hydrogen atom can be obtained by

- (1) $E_n = \frac{13.6}{n^2} \text{ eV}$
- (2) $E_n = -\frac{13.6}{n^2} \text{ eV}$
- (3) $E_n = -\frac{1.36}{n^2} \text{ eV}$
- (4) $E_n = -13.6 \times n^2 \text{ eV}$

Ans. (2)

Sol. For hydrogen

$E = -\frac{13.6}{n^2} \text{ eV}$

155. The length of the string of a musical instrument is 90 cm and has a fundamental frequency of 120 Hz. Where should it be pressed to produce fundamental frequency of 180 Hz ?

- (1) 75 cm (2) 60 cm
(3) 45 cm (4) 80 cm

Ans. (2)

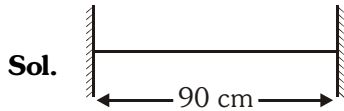

$$f = 120 \text{ Hz} = \frac{V}{2\ell}$$

$$120 = \frac{V}{2(0.9)}$$

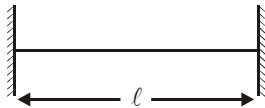

$$f = 180 \text{ Hz} = \frac{V}{2\ell}$$

$$180 = \frac{120 \times 0.9}{\ell}$$

$$\ell = 60 \text{ cm}$$

156. The acceleration of an electron due to the mutual attraction between the electron and a proton when they are 1.6 \AA apart is, ($m_e \approx 9 \times 10^{-31} \text{ kg}$,

$$e = 1.6 \times 10^{-19} \text{ C}) \text{ (Take } \frac{1}{4\pi\epsilon_0} = 9 \times 10^9 \text{ Nm}^2 \text{ C}^{-2})$$

- (1) 10^{24} m/s^2 (2) 10^{23} m/s^2
(3) 10^{22} m/s^2 (4) 10^{25} m/s^2

Ans. (3)

Sol. $F = K \frac{e^2}{r^2}$

$$a = K \frac{e^2}{mr^2}$$

$$a = 9 \times 10^9 \frac{(1.6 \times 10^{-19})^2}{(1.6 \times 10^{-10})^2 (9 \times 10^{-31})}$$

$$a = 10^{-29} \times 10^{51} = 10^{22} \text{ m/s}^2$$

157. The wave nature of electrons was experimentally verified by,

- (1) de Broglie
(2) Hertz
(3) Einstein
(4) Davisson and Germer

Ans. (4)

Sol. Davisson and Germer

158. Two solid conductors are made up of same material, have same length and same resistance. One of them has a circular cross section of area A_1 and the other one has a square cross section of area A_2 . The ratio A_1/A_2 is

- (1) 1.5 (2) 1
(3) 0.8 (4) 2

Ans. (2)

Sol. $R = \rho \frac{\ell}{A}$

$$R_1 = R_2$$

$$\frac{1}{A_1} = \frac{1}{A_2}$$

$$\frac{A_1}{A_2} = 1$$

159. For the circuit given below, the Kirchoff's loop rule for the loop BCDEB is given by the equation

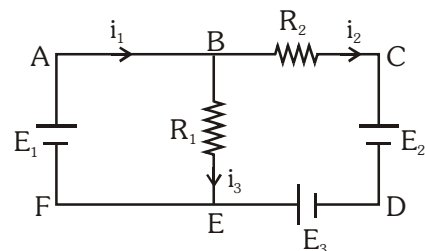

- (1) $-i_2R_2 + E_2 - E_3 + i_3R_1 = 0$
(2) $i_2R_2 + E_2 - E_3 - i_3R_1 = 0$
(3) $i_2R_2 + E_2 + E_3 + i_3R_1 = 0$
(4) $-i_2R_2 + E_2 + E_3 + i_3R_1 = 0$

Ans. (2)

Sol. By KVL

$$-i_2R_2 - E_2 + E_3 + i_3R_1 = 0$$

or

$$i_2R_2 + E_2 - E_3 - i_3R_1 = 0$$

- 160.** Three stars A, B, C have surface temperatures T_A , T_B , T_C respectively. Star A appears bluish, star B appears reddish and star C yellowish. Hence,
 (1) $T_A > T_B > T_C$ (2) $T_B > T_C > T_A$
 (3) $T_C > T_B > T_A$ (4) $T_A > T_C > T_B$

Ans. (4)



$$T_A > T_C > T_B$$

- 161.** A liquid does not wet the solid surface if angle of contact is :
 (1) equal to 45° (2) equal to 60°
 (3) greater than 90° (4) zero

Ans. (3)

Sol. When angle of contact $\geq 90^\circ$ then liquid doesn't wet solid.

- 162.** A point mass 'm' is moved in a vertical circle of radius 'r' with the help of a string. The velocity of the mass is $\sqrt{7gr}$ at the lowest point. The tension in the string at the lowest point is :
 (1) 6 mg (2) 7 mg
 (3) 8 mg (4) 1 mg

Ans. (3)

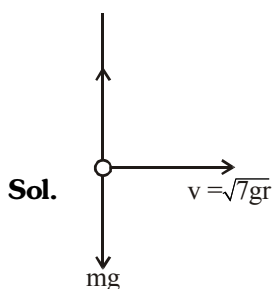

$$T - mg = \frac{m(\sqrt{7gr})^2}{r}$$

$$T = 8 \text{ mg}$$

- 163.** An object is placed on the principal axis of a concave mirror at a distance of $1.5f$ (f is the focal length). The image will be at,
 (1) $-3f$ (2) $1.5f$
 (3) $-1.5f$ (4) $3f$

Ans. (1)

Sol. $u = -1.5f$

$$\frac{1}{u} + \frac{1}{v} = \frac{1}{f}$$

$$\frac{1}{-1.5f} + \frac{1}{v} = \frac{1}{-f}$$

$$\Rightarrow \frac{1}{v} = -\frac{1}{f} + \frac{1}{1.5f}$$

$$\frac{1}{v} = \frac{-1.5 + 1}{1.5f} = \frac{-0.5}{1.5f}$$

$$v = -3f$$

- 164.** The half life of radioactive sample undergoing α -decay is 1.4×10^{17} s. If the number of nuclei in the sample is 2.0×10^{21} , the activity of the sample is nearly :

- (1) 10^4 Bq (2) 10^5 Bq
 (3) 10^6 Bq (4) 10^3 Bq

Ans. (1)

Sol. $R = \lambda N$

$$R = \frac{0.693}{T} \times N$$

$$R = \frac{0.693}{1.4 \times 10^{17}} \times 2 \times 10^{21}$$

$$R = 10^4$$

- 165.** If the critical angle for total internal reflection from a medium to vacuum is 45° , then velocity of light in the medium is,

- (1) $1.5 \times 10^8 \text{ m/s}$ (2) $\frac{3}{\sqrt{2}} \times 10^8 \text{ m/s}$
 (3) $\sqrt{2} \times 10^8 \text{ m/s}$ (4) $3 \times 10^8 \text{ m/s}$

Ans. (2)

Sol. $\sin \theta_c = \frac{1}{\mu}$

$$\mu = \frac{1}{\sin \theta_c} = \frac{1}{\sin 45^\circ} = \frac{1}{(1/\sqrt{2})} = \sqrt{2}$$

$$\mu = \frac{c}{v} \Rightarrow v = \frac{c}{\mu} = \frac{3 \times 10^8}{\sqrt{2}} \text{ m/sec}$$

166. A wheel with 20 metallic spokes each 1 m long is rotated with a speed of 120 rpm in a plane perpendicular to a magnetic field of 0.4 G. The induced emf between the axle and rim of the wheel will be, (1 G = 10⁻⁴ T)

- (1) 2.51 × 10⁻⁴ V (2) 2.51 × 10⁻⁵ V
 (3) 4.0 × 10⁻⁵ V (4) 2.51 V

Ans. (1)

Sol. $\epsilon = \frac{1}{2} B \omega r^2$

$$\epsilon = \frac{1}{2} \times (0.4 \times 10^{-4}) \times \left(2\pi \left[\frac{120}{60} \right] \right) (1)^2$$

$$\epsilon = 0.8\pi \times 10^{-4}$$

$$\epsilon = 2.512 \times 10^{-4} \text{ Volt}$$

167. An ideal gas equation can be written as $P = \frac{\rho RT}{M_0}$ where ρ and M_0 are respectively,

- (1) mass density, mass of the gas
 (2) number density, molar mass
 (3) mass density, molar mass
 (4) number density, mass of the gas

Ans. (3)

Sol. $PV = nRT$

$$\Rightarrow P = \frac{1}{V} \cdot \frac{m}{M_0} \cdot RT$$

$$= \left(\frac{m}{V} \right) \left(\frac{RT}{M_0} \right)$$

$$\Rightarrow P = \frac{\rho RT}{M_0}$$

$$\rho = \frac{m}{v} = \text{mass density}$$

$M_0 = \text{molar mass}$

168. The variation of electrostatic potential with radial distance r from the centre of a positively charged metallic thin shell of radius R is given by the graph

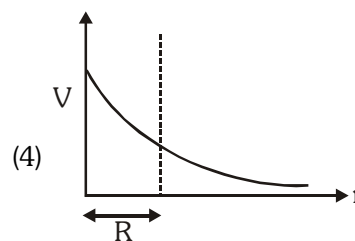
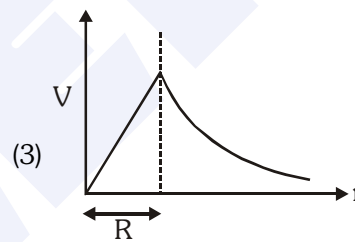
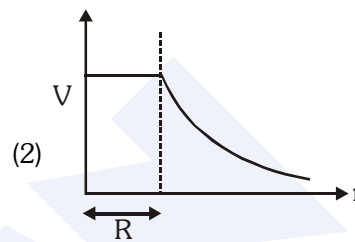
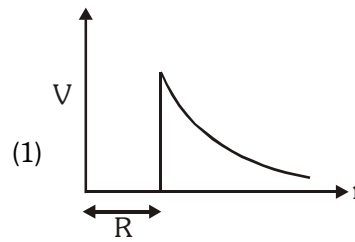

Ans. (2)

Sol. $V_{in} = V_s = \frac{KQ}{R}$ and $V_{out} = \frac{KQ}{r}$ ($r > R$)

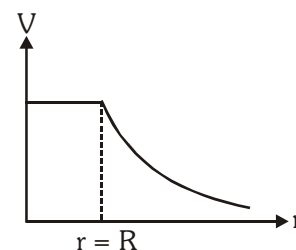

169. Which of the following gate is called universal gate?

- (1) OR gate (2) AND gate
 (3) NAND gate (4) NOT gate

Ans. (3)

Sol. NAND gate and NOR gate are universal logic gates.

170. The P-V diagram for an ideal gas in a piston cylinder assembly undergoing a thermodynamic process is shown in the figure. The process is

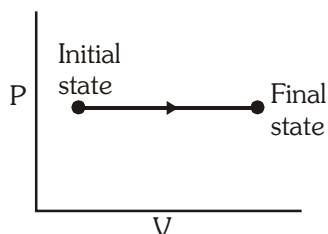

- (1) adiabatic (2) isochoric
(3) isobaric (4) isothermal

Ans. (3)

Sol. $P = \text{constant} \Rightarrow$ Isobaric process

171. The power of a biconvex lens is 10 dioptre and the radius of curvature of each surface is 10 cm. Then the refractive index of the material of the lens is,

- (1) $\frac{4}{3}$ (2) $\frac{9}{8}$ (3) $\frac{5}{3}$ (4) $\frac{3}{2}$

Ans. (4)

Sol. $P = \frac{100}{f} \Rightarrow f = \frac{100}{P} = \frac{100}{10} = 10 \text{ cm}$

$$f = \frac{R}{2(\mu - 1)} \text{ (for equiconvex lens)}$$

$$10 = \frac{10}{2(\mu - 1)}$$

$$(\mu - 1) = \frac{1}{2} \Rightarrow \mu = \frac{1}{2} + 1 = \frac{3}{2}$$

172. An intrinsic semiconductor is converted into n-type extrinsic semiconductor by doping it with :-

- (1) Phosphorous (2) Aluminium
(3) Silver (4) Germanium

Ans. (1)

Sol. For N type semi-conductor intrinsic semiconductor doped by pentavalent impurity.

173. A barometer is constructed using a liquid (density = 760 kg/m^3). What would be the height of the liquid column, when a mercury barometer reads 76 cm ?

(density of mercury = 13600 kg/m^3)

- (1) 1.36 m
(2) 13.6 m
(3) 136 m
(4) 0.76 m

Ans. (2)

Sol. $76 \text{ cm} \times \rho_{\text{Hg}} \times g = h \times \rho_L \times g$

$$h = 76 \text{ cm} \times \frac{\rho_{\text{Hg}}}{\rho_L}$$

$$= 76 \text{ cm} \times \frac{13600}{760}$$

$$= 13.6 \text{ m}$$

174. A wire of length L metre carrying a current of I ampere is bent in the form of a circle. Its magnetic moment is,

- (1) $I L^2 / 4 \text{ A m}^2$
(2) $I \pi L^2 / 4 \text{ A m}^2$
(3) $2 I L^2 / \pi \text{ A m}^2$
(4) $I L^2 / 4\pi \text{ A m}^2$

Ans. (4)

Sol. $2\pi r = L$

$$r = \frac{L}{2\pi}$$

$$M = I (A)$$

$$M = I (\pi r^2)$$

$$M = I (\pi) \left(\frac{L}{2\pi} \right)^2$$

$$M = \frac{I L^2}{4\pi}$$

175. A parallel plate capacitor having cross-sectional area A and separation d has air in between the plates. Now an insulating slab of same area but thickness $d/2$ is inserted between the plates as shown in figure having dielectric constant $K (= 4)$. The ratio of new capacitance to its original capacitance will be,

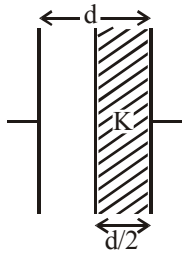

- (1) 2 : 1 (2) 8 : 5
 (3) 6 : 5 (4) 4 : 1

Ans. (2)

Sol. $C_a = \frac{\epsilon_0 A}{d}$

$$C_k = \frac{\epsilon_0 A}{d - t + \frac{t}{k}}$$

$$C_k = \frac{\epsilon_0 A}{d - \frac{d}{2} + \frac{d}{8}}$$

$$C_k = \frac{8 \epsilon_0 A}{5 d}$$

$$C_k = \frac{8}{5} C_a$$

$$\frac{C_k}{C_a} = \frac{8}{5}$$

176. What is the depth at which the value of acceleration due to gravity becomes $1/n$ times the value that at the surface of earth? (radius of earth = R)

- (1) R/n^2
 (2) $R(n - 1)/n$
 (3) $Rn/(n - 1)$
 (4) R/n

Ans. (2)

Sol. At depth :

$$g_{\text{eff}} = g \left(1 - \frac{d}{R} \right)$$

$$\frac{g}{n} = g \left(1 - \frac{d}{R} \right)$$

$$d = (n - 1) R/n$$

177. Time intervals measured by a clock give the following readings :

1.25 s, 1.24 s, 1.27 s, 1.21 s and 1.28 s.

What is the percentage relative error of the observations ?

- (1) 2 %
 (2) 4 %
 (3) 16 %
 (4) 1.6 %

Ans. (4)

Sol. Mean of observation

$$= \frac{1.25 + 1.24 + 1.27 + 1.21 + 1.28}{5}$$

$$= 1.25 \text{ sec.}$$

Mean of error

$$= \frac{0 + 0.01 + 0.02 + 0.04 + 0.03}{5}$$

$$= \frac{0.1}{5}$$

$$\% \text{ error} = \frac{0.1 \times 100}{5 \times 1.25} = 1.6\%$$

178. Three identical spheres, each of mass M , are placed at the corners of a right angle triangle with mutually perpendicular sides equal to 2 m (see figure). Taking the point of intersection of the two mutually perpendicular sides as the origin, find the position vector of centre of mass.

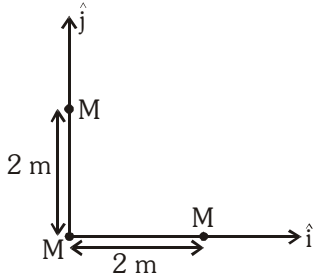

- (1) $2(\hat{i} + \hat{j})$ (2) $(\hat{i} + \hat{j})$
 (3) $\frac{2}{3}(\hat{i} + \hat{j})$ (4) $\frac{4}{3}(\hat{i} + \hat{j})$

Ans. (3)

Sol.

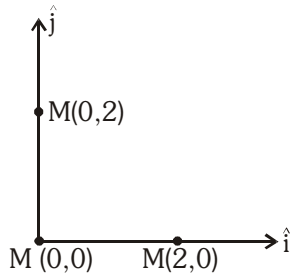

$$x_{\text{com}} = \frac{M \times 0 + M \times 2 + M \times 0}{3M} = \frac{2}{3}$$

$$y_{\text{com}} = \frac{M \times 0 + M \times 2 + M \times 0}{3M} = \frac{2}{3}$$

$$\text{Position vector} = \frac{2}{3}\hat{i} + \frac{2}{3}\hat{j}$$

179. The equivalent resistance between A and B for the mesh shown in the figure is

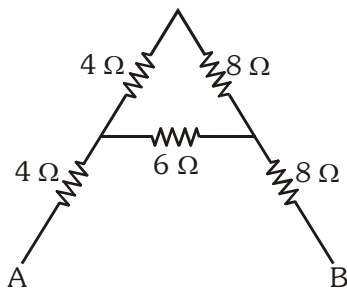

- (1) $7.2\ \Omega$ (2) $16\ \Omega$
 (3) $30\ \Omega$ (4) $4.8\ \Omega$

Ans. (2)

Sol.

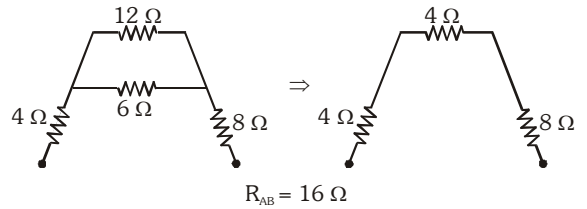

180. Calculate the acceleration of the block and trolley system shown in the figure. The coefficient of kinetic friction between the trolley and the surface is 0.05 . ($g = 10\text{ m/s}^2$, mass of the string is negligible and no other friction exists).

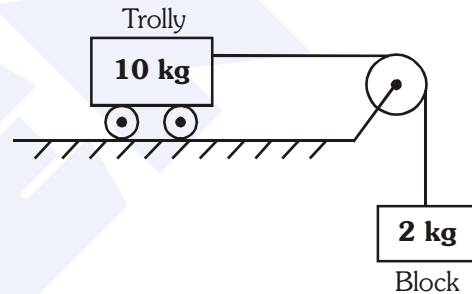

- (1) 1.25 m/s^2
 (2) 1.50 m/s^2
 (3) 1.66 m/s^2
 (4) 1.00 m/s^2

Ans. (1)

Sol.

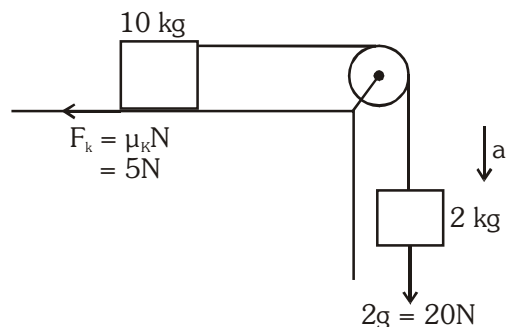

$$a = \frac{20 - 5}{12} = 1.25\text{ m/s}^2$$